

MODEL 40 POWER TAKE-OFF FOR ALL WILLYS 4x4 TRUCKS, UTILITY WAGON AND UTILITY DELIVERY

Included in Model 840RT King Winch Assembly

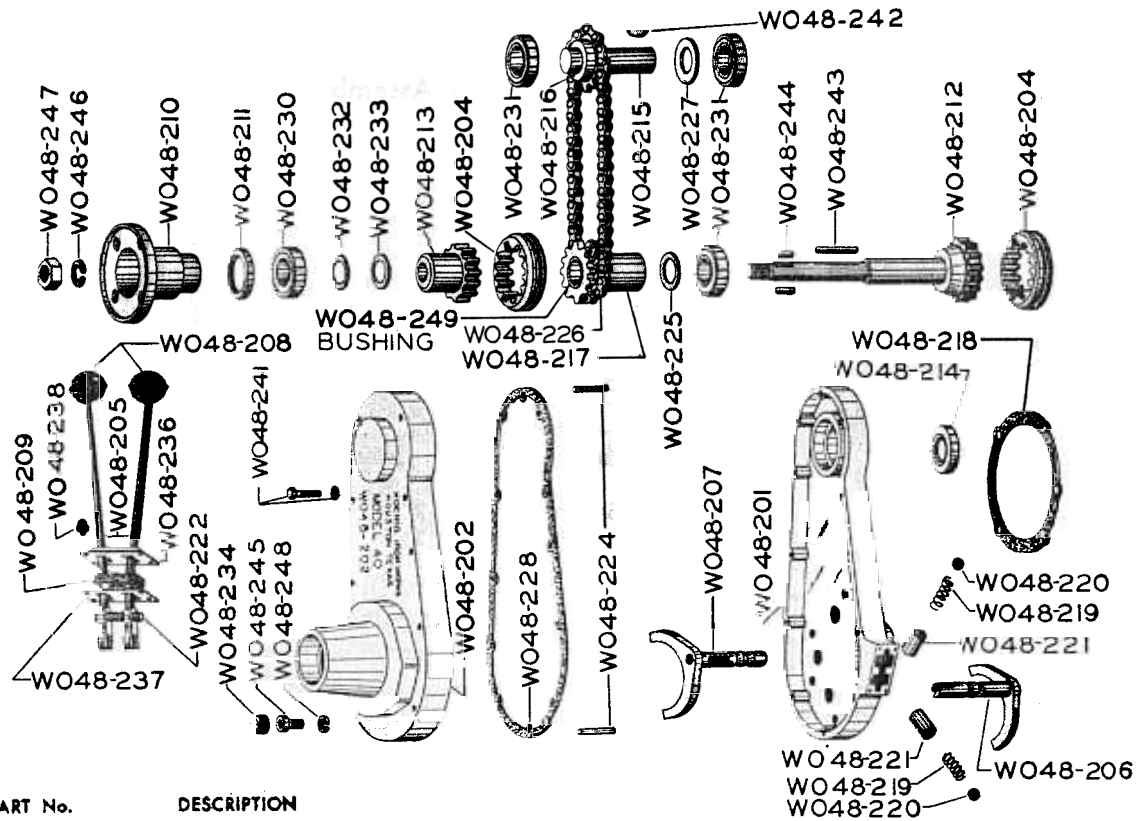

PART No. DESCRIPTION

WO48-201	Housing—Front half
WO48-202	Housing—Rear half
WO48-203	Housing Assembly
WO48-204	Sliding Ring (2 req.)
WO48-205	Lever (2 req.)
WO48-206	Shifter—to engine
WO48-207	Shifter—for winch
WO48-208	Knob (2 req.)
WO48-209	Felt oil retainer for levers
WO48-210	Coupling
WO48-211	Oil Seal—2" OD x 1½" ID
WO48-212	Main P.T.O. Shaft
WO48-213	Clutch Gear Hub
WO48-214	Oil Seal—1⅞" OD x 1" ID
WO48-215	P.T.O. Shaft—1" x 3¼"
WO48-216	Sprocket—16 tooth
WO48-217	Clutch Sprocket Hub
WO48-218	Gasket—Between P.T.O. and transmission
WO48-219	Spring (2 req.)
WO48-220	Ball (2 req.)
WO48-221	Bushing for shifter ball and spring (2 req.)
WO48-222	Pin
WO48-224	Dowel Pin (2 req.)
WO48-225	Thrust Washer—1" x 1⅞" x .040"
WO48-226	Roller Chain and connecting link
WO48-227	P.T.O. Shaft Spacer—1" x 1⅞" x .189"

THIS POWER TAKE-OFF IS FURNISHED WITH MODEL 840RT KING WINCH ASSEMBLY, AND IS SUITABLE FOR DRIVING THE KING WINCH ON THE FRONT, AND ANY OTHER EQUIPMENT ON THE REAR OF THE TRUCK. HAS THREE SPEEDS FORWARD, ONE SPEED REVERSE (BY USE OF REGULAR TRUCK TRANSMISSION).

This power take-off is lubricated from transfer case by oil passage holes. Check oil level in transfer case after operating a short time.

PART No.

DESCRIPTION	
WO48-228	Gasket—Between Housing
WO48-230	Ball bearing—⅞" ID
WO48-231	Ball Bearing—1" ID (3 req.)
WO48-232	Shim—.010" thick brass (2 req.)
WO48-233	Shim—.046" thick (2 req.)
WO48-234	⅜" pipe plug (5 req.)
WO48-236	Shifter plate—top
WO48-237	Shifter plate—bottom
WO48-238	Shifter Plate Screws and Washers (4 req.)
WO48-239	Connecting Link
WO48-240	Set screw for WO48-216 sprocket
WO48-241	Cap Screw (10 req.)
WO48-242	Woodruff Key—#15 (2 req.)
WO48-243	Key—for WO48-213
WO48-244	Key for WO48-210 (2 req.)
WO48-245	Socket cap screw (5 req.)
WO48-246	Lock Washer
WO48-247	Nut—⅝" N. F.
WO48-248	Lock Washer—⅝" Hi-Coller (5 req.)
WO48-249	Bronze bushing—1" x 1¼" x 1¼" (2 req.)

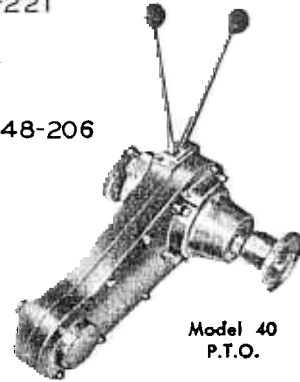

Model 40 P.T.O.

Koenig

IRON WORKS, inc.