

**MODELS 130J, 131J, AND 138J KING WINCHES FOR CJ-2A, CJ-3A,  
 AND CJ-3B 'JEEP' UNIVERSAL**

KING Winch Models 130J, 131J, and 138J, have two 1/4" spacers (see Sketch A) and two adapter brackets (see Sketch B). These parts are factory installed.

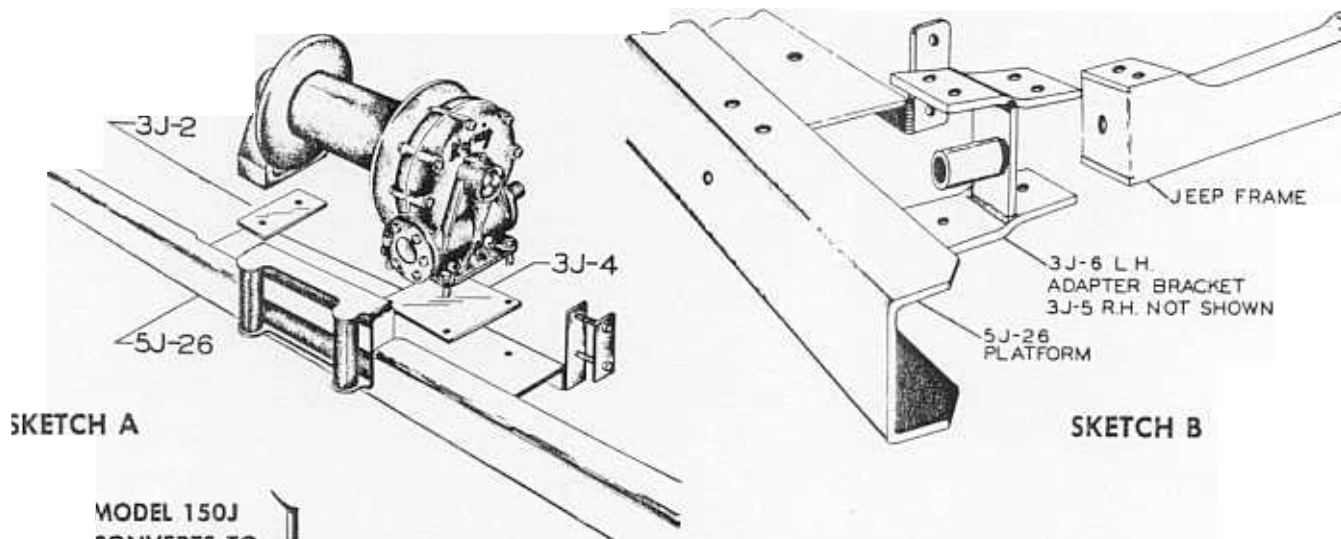

MODEL 150J  
 CONVERTS TO  
 MODEL 130J

MODEL 151J  
 CONVERTS TO  
 MODEL 131J

MODEL 158J  
 CONVERTS TO  
 MODEL 138J

BY ADDING GROUP  
 NO. 3J2456

- GROUP NO. 3J2456**
- 1-3J2 SPACER
  - 1-3J4 SPACER
  - 1-3J5 R.H. ADAPTOR BRACKET
  - 1-3J6 L.H. ADAPTOR BRACKET

When installing a Model 130J, 131J, or 138J on a CJ-2A, it is necessary to drill three holes in each end of the vehicle frame through the 3J-5 and 3J-6 adapter bracket. (If desired, these adapter brackets can be welded to the end of the vehicle frame.)

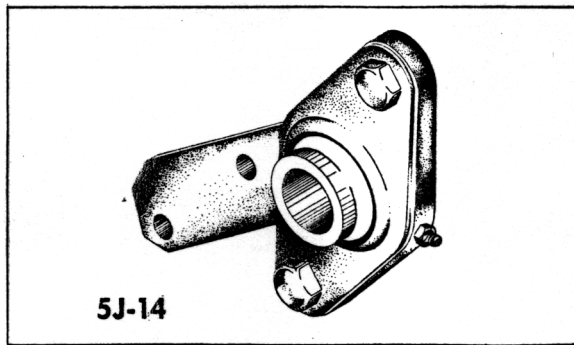

5J-14

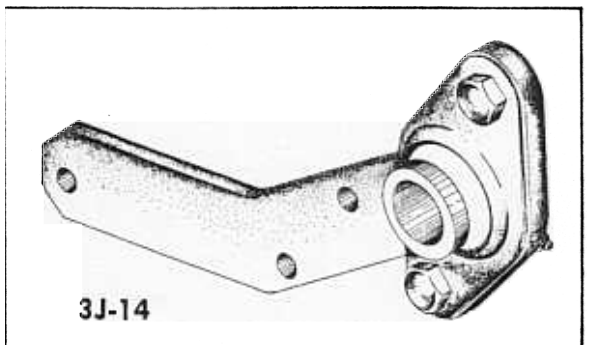

3J-14

The 5J-14 bearing fits the CJ-3B, CJ-5, and CJ-6 'JEEP' Universal. For the CJ-2A or CJ-3A, specify bearing 3J-14.

NOTE: This entire installation will transfer to a CJ-5 or CJ-6 by removing two spacers (see Sketch A), and two adapter brackets (see Sketch B).